

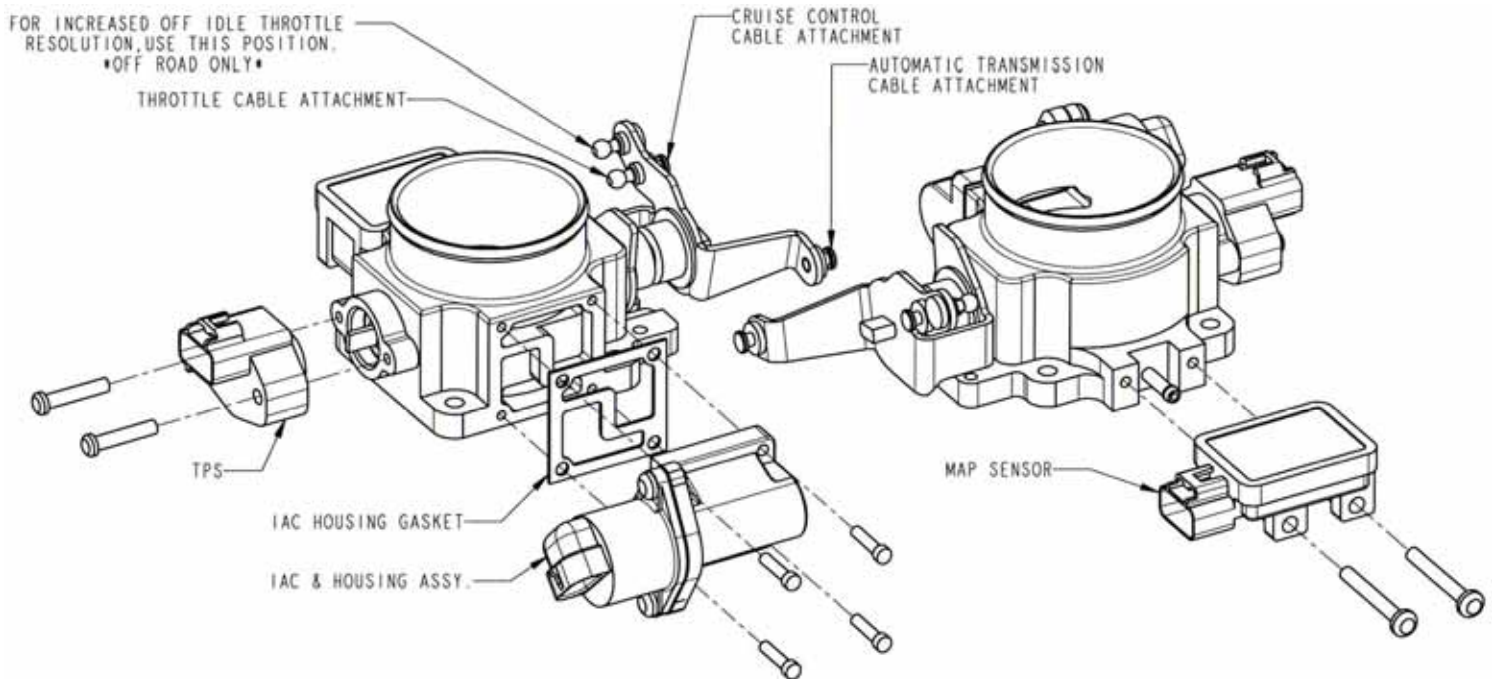

RUBICON MANUFACTURING INC. 3290 MONIER CR. RANCHO CORDOVA, CA. 95742 916-473-4600

INSTALLATION INSTRUCTIONS FOR RE1062 THROTTLE BODY



1. Using a standard screwdriver, loosen the clamp attaching the air intake tube to the factory throttle body. Remove the air intake tube from the factory throttle body.
2. Using a 10mm socket or wrench, remove the (4) bolts attaching the factory throttle body to the intake manifold, set aside. These bolts will be used to attach the Rubicon 62mm throttle body to the intake manifold.
3. Set aside the factory throttle body gasket (gasket between the throttle body and the intake manifold).
4. Disconnect the electrical connectors that attach to the IAC and TPS sensors.
5. If the vehicle is equipped with a throttle body mounted MAP sensor, disconnect the electrical that is attached to this sensor.
6. Remove the throttle cable from the factory throttle body. If vehicle is equipped with automatic transmission and cruise control, remove these cables from the throttle body.
7. Using the #20 torx wrench (included with the Rubicon throttle body) remove the IAC housing from the factory throttle body, discard IAC housing gasket and set aside the IAC housing assembly.
8. Using the #20 torx wrench, remove the TPS from the factory throttle body, set aside.
9. If vehicle is equipped with a throttle body mounted MAP sensor, remove this sensor using the #20 torx wrench.
10. Using the #20 torx wrench, attach the IAC housing and the new IAC gasket to the Rubicon throttle body.
11. Using the #20 torx wrench, attach the TPS and MAP sensors to the Rubicon throttle body (if your factory throttle body was not equipped with a MAP sensor, install the rubber cap, included with the Rubicon throttle body, over the vacuum nipple).
12. Using a 10mm socket or wrench, attach the Rubicon throttle body and throttle body gasket to the intake manifold.
13. Re-attach the electrical connectors to the IAC and TPS sensors.
14. If vehicle is equipped with a throttle body mounted map sensor, re-connect the electrical connector to this sensor.
15. Attach the throttle cable to the Rubicon throttle body. If equipped with an automatic transmission and or cruise control, attach these cables to their respective locations.
16. Re-install the air intake tube, and tighten clamp.
17. Before starting vehicle, re-check all fasteners and electrical connectors. Make sure all fasteners are tight and all electrical connectors are properly plugged in.